

## 拉布機安裝手冊

THE INSTALLATION GUIDE BOOK

INSTALLIERUNG DER EINZUGSVORRICHTUNG

GUIDE D'INSTALLATION DES MÉCANISMES D'ENTRAÎNEMENT

GUÍA DE INSTALACIÓN DE LOS MECANISMOS

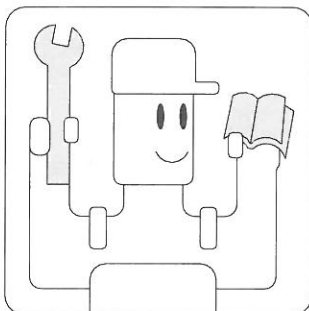
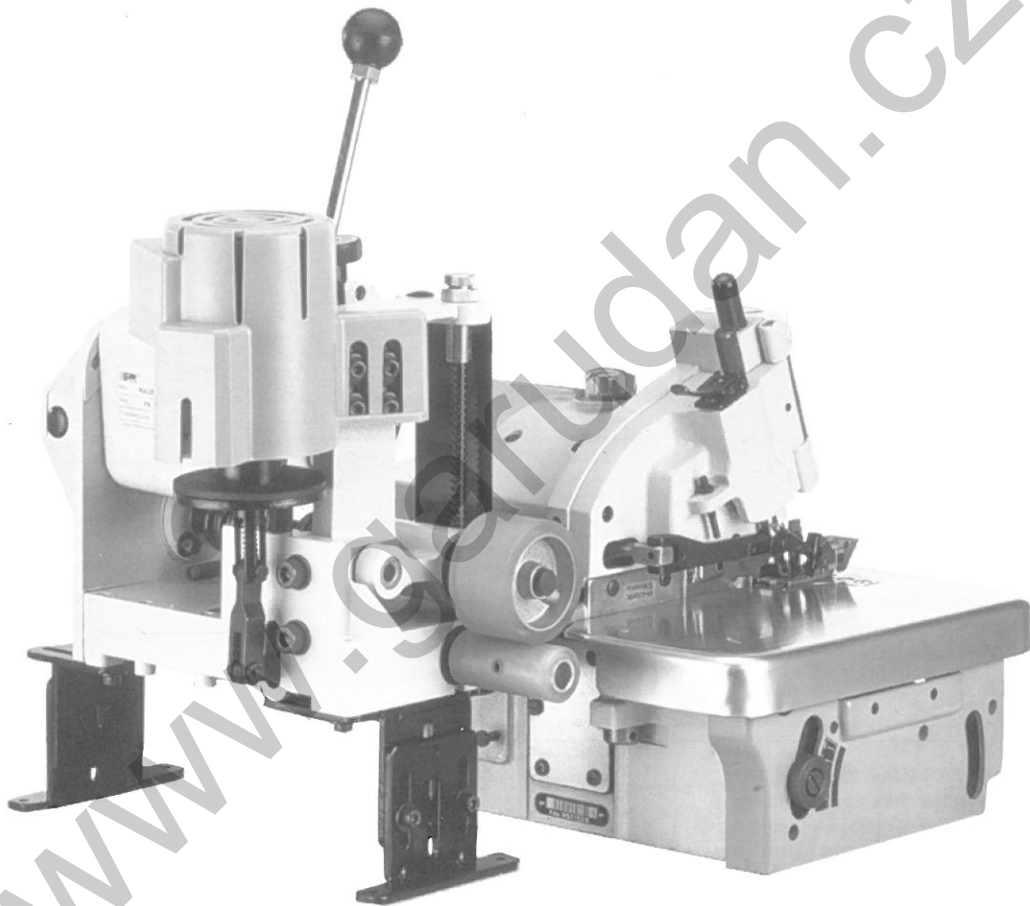

- 安裝前，請詳細閱讀安裝說明書
- PLEASE READ INSTRUCTIONS & ASSOCIATED DRAWINGS BEFORE INSTALLATION
- VOR AUFSTELLUNG LESEN SIE BITTE DIE ANLEITUNGEN UND DIE DAZUGEHÖRIGEN ZEICHNUNGEN
- VEUILLEZ LIRE LES DIRECTIVEES ET LES SCHÉMAS D'ASSEMBLAGE ATTENTIVEMENT AVANT DE PROCÉDER À L'INSTALLATION
- POR FAVOR LEA LAS INSTRUCCIONES DE LOS ESQUEMAS ANTES DE INSTALARLO

## 目 錄

CONTENTS  
INHALTSVERZEICHNISTABLE DES MATIERES  
CONTENIDO

		頁 數
		Page Page
		Seite Página
組 合 圖 -----		1
Combination	Combinaison	
Kombination	Combinación	
安 裝 步 驟 -----		2-3
Installation instruction	Instructions d'installation	
Installierung	Instrucciones de instalación	
調 整 -----		4
Adjusting	Ajustement	
Justieren	Ajuste	
配 線 圖 -----		5-6
Wiring diagram	Schema de montage	
Schaltplan	Diadrama de instalación	
零 件 圖 -----		7
Parts list	Liste des pieces	
Auflistung der teile	Listado de piezas	
拉 布 輪 編 號 圖 -----		8
Roller list	Liste des rouleaux	
Auflistung der rollen	Listado de rodillos	
電 控 配 件 編 號 圖 -----		9
Electric components	Composantes Électriques	
Elektrische teile	Componentes eléctricos	
故 障 排 除 -----		10-11
Solution for error function	Détection des problemes	
Problemlösung	Localización de los problemas	

www.garudan.cz



# PK 系列組合圖

THE COMBINATION OF PK SERIES  
KOMBINATION DER PK SERIE

COMBINAISON DES SERIES PK  
COMBINACIÓN DE LAS SERIES PK

請依照編號順序組合

Assemble the puller according to the indicated numbers  
Zusammenbau der Einzugsvorrichtung  
Instructions d'assemblage du mécanisme d'entraînement  
Instrucciones de ensamblaje de los tiradores

選擇性配件  
Optional parts  
Fakultative Teile  
Pièces optionnelles  
Piezas opcionales

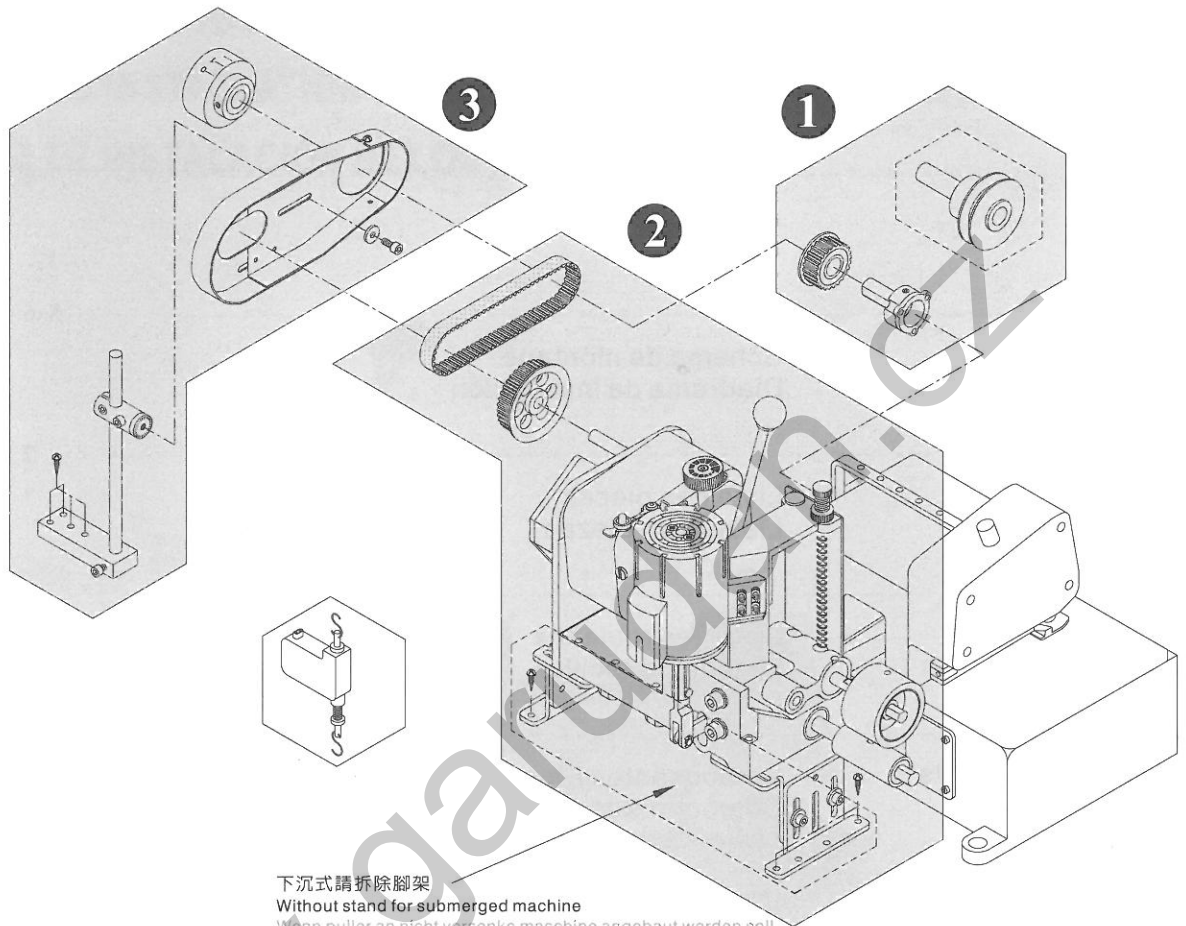

下沉式請拆除腳架  
Without stand for submerged machine  
Wenn puller an nicht versenke maschine angebaut werden soll  
Sans bâti pour machine intégré  
Sin base para sistema sumergido

浮出式  
Floating type  
Schwebende Ausführung  
Montage Semi-submergé  
Normal

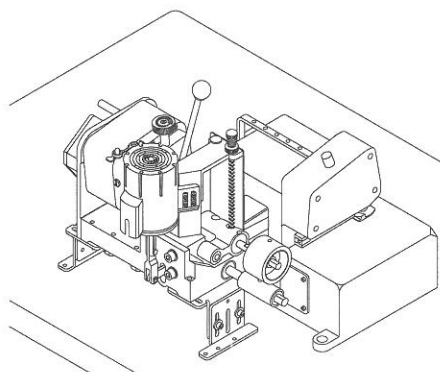

下沉式  
Submerged type  
Modèle encastré  
Vollversenkte Ausstellung  
De tipo sumergido

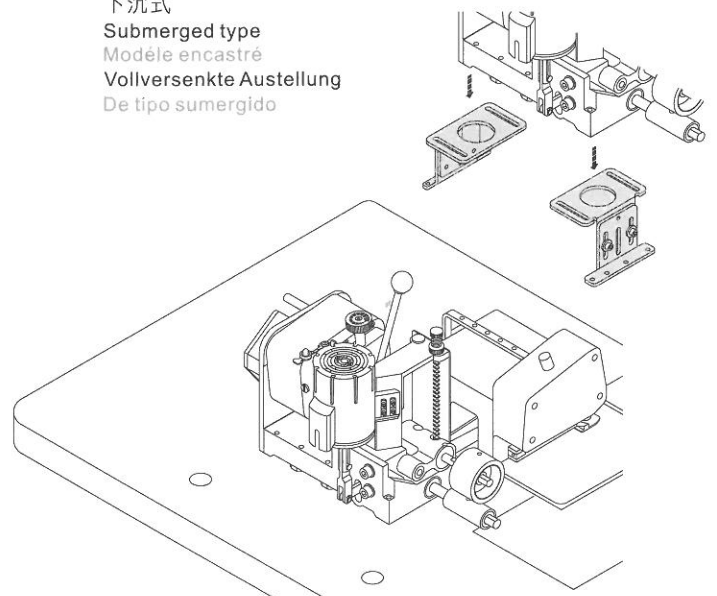

# 安裝步驟

## INSTALLATION INSTRUCTION INSTALLIERUNG

## INSTRUCTIONS D'INSTALLATION INSTRUCCIONES DE INSTALACIÓN

**1**

上螺柱 (螺柱為選擇性配件)

Put stud on (stud is optional parts)

Stifte für übergroße antriebsscheiben fakul ative teile

Goujons pour poulies pièces optionnelles

Pernos para poleas piezas opcionales

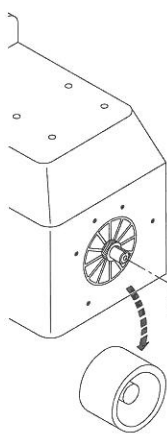

例 1

Example 1

Beispiel 1

Exemple 1

Ejemplo 1

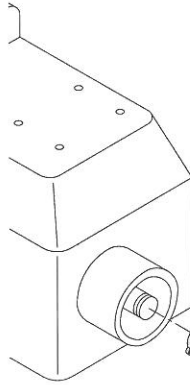

例 2

Example 2

Beispiel 2

Exemple 2

Ejemplo 2

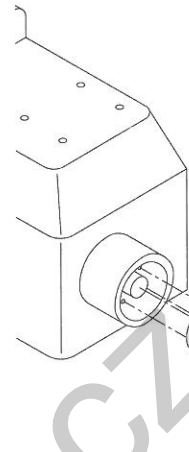

例 3

Example 3

Beispiel 3

Exemple 3

Ejemplo 3

**2-1**

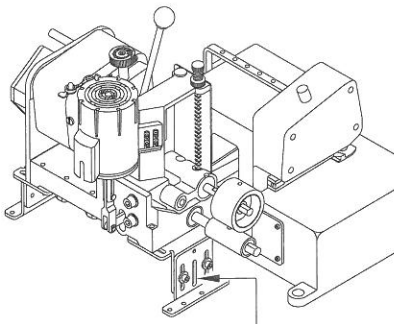

調整高低水平

Adjusting high, low & parallel

Einstellung hoch/tief & parallel

Réglage du haut, bas et parallèle

Ajustase superior, inferior y paralelo

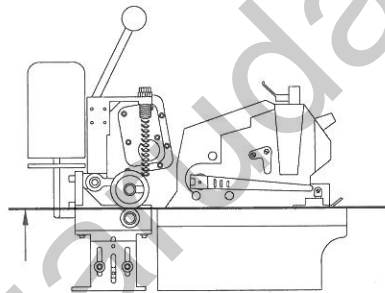

高低

High & low

Hoch & tief

Haut et bas

Superior e inferior

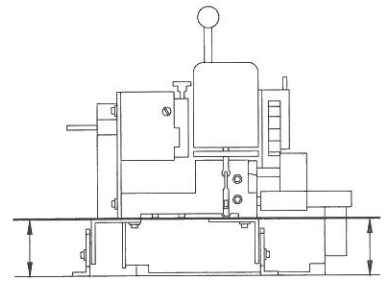

水平

Parallel

Parallèle

Parallèle

Paralelo

**2-2**

暫勿上緊螺絲直到第 2-6 步驟

Do not tighten the screw until no. 2-6

Diese Schraube erst später anziehen 2-6

Attendre à plus tard pour serrer cette vis 2-6

Debe esperarse a más tarde para apretar este tornillo 2-6

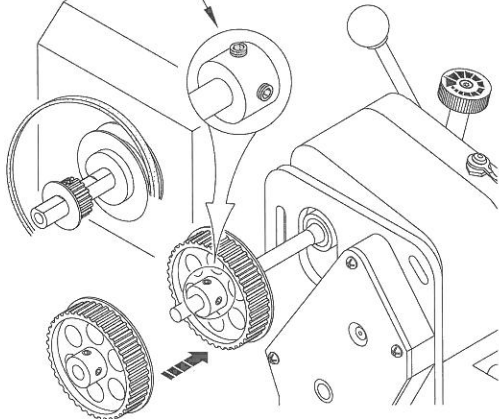

**2-3**

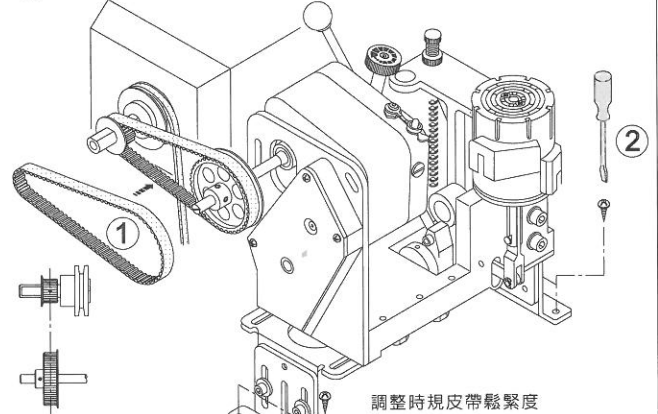

時規齒輪要成平行

Timing gears must be parallel

Das steuerungsgestänge muß genau

synchronisiert sein

Les engrenages de distribution doivent être

parfaitement alignés

Los engranes de sincronización deben estar

perfectamente alineados

調整時規皮帶鬆緊度

Adjust tension of timing belt

Spannung des Übertragungsriemens

einstellen

La tension de la courro d'ajustement

Reglaie dela correa de trans

2 -4

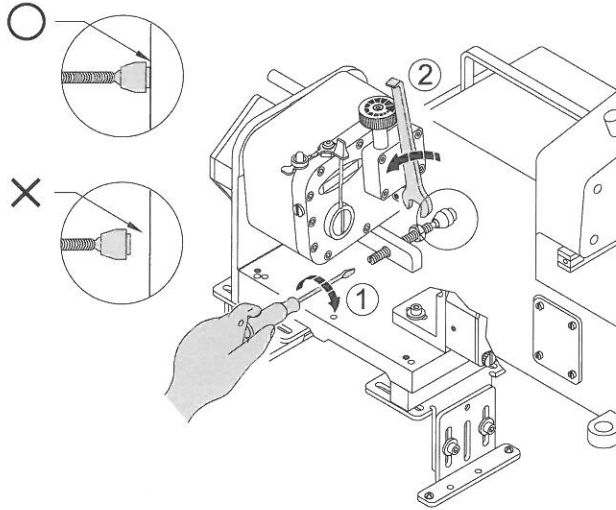

2 -5

調整時規皮帶鬆緊度  
Adjust tension of timing belt  
Spannung des Übertragungsriemens einstellen  
La tension de la courroie d'ajustement  
Reglaie dela correa de trans

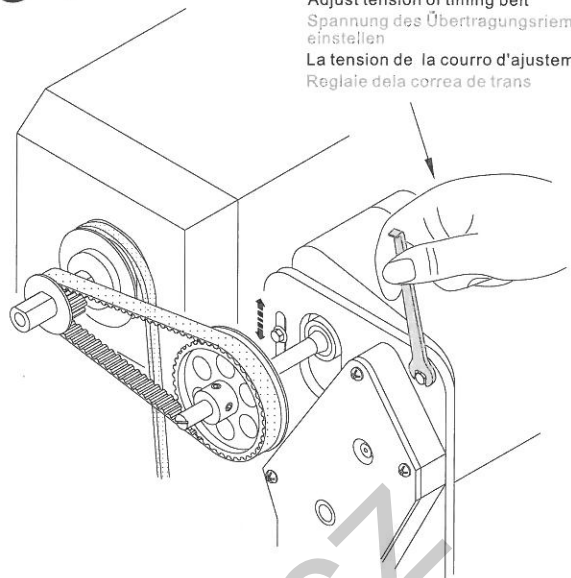

2 -6

入力軸定位  
Adjust input shaft position  
Position der antriebswelle  
Régler la position de l'arbre d'entrée  
Ajustar la posición del eje de entrada

變速機紅線對齊輸入軸紅線後，上緊時規齒輪螺絲  
Meet the both red line on transmission input shaft, tighten the timing gear screw  
Wenn sich die roten Linien berühren, Schraube des des Steuerungsgestänges anziehen  
Quand les 2 lignes rouges se rencontrent, serrer la vis de l'engrenage de distribution  
Cuando las dos líneas rojas se tocan, apretar el tornillo del engrane de sincronización

- ① 車針提升至最高點  
Needle to the toppest position  
Nadel in ihre höchste stellung bringen  
Placer l'aiguille à sa position la plus haute  
Colocar la aguja sobre su más alta posición

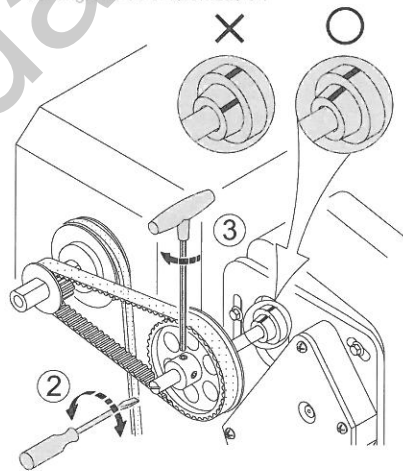
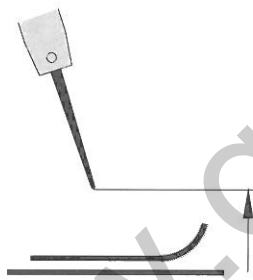

警告  
CAUTION ATTENTION  
WARNUNG ADVERTENCIA

保護裝置務必安裝否則會造成傷害  
Danger of injury without safety device  
Es ist gefährlich die maschine ohne sicherheitseinrichtung zu benutzen  
Risque d'accident sans protection  
Peligro de lesión sin dispositivo de seguridad

3

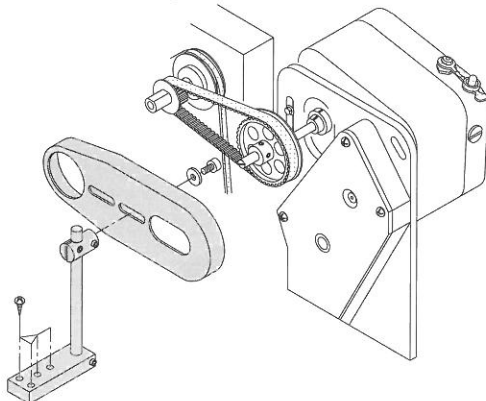

拉布輪的動作量應比送齒稍大,但差率太多時拉布輪及布料則易磨損

The puller's feeding amount should be properly larger than feed dog's to procure even effect on sewn material. But if it is overmuch, either sewn material or roller will be torn easily.

Stellen sie die Geschwindigkeit der Einzugsvorrichtung so ein, daß sich der Stoff nicht kräuselt. eine zu hohe Geschwindigkeit kann den Stoff beschädigen oder frühzeitige Abnutzung der Rollen verursachen.

Réglez le régime d'alimentation du mécanisme d'entraînement pour que le tissu ne fasse pas de faux plis. un régime trop élevé peut endommager le tissu et/ou causer l'usure prématurée du rouleau.

Ajustar el régimen de alimentación del tirador para que la tela no se frunza. una velocidad demasiado alta puede estropear la tela y lo causar un desgaste prematuro de los rodillos.

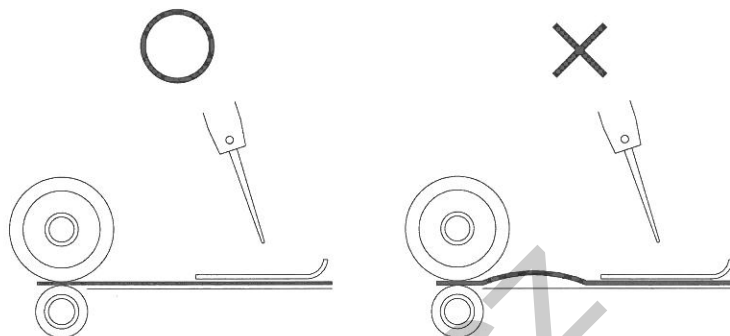
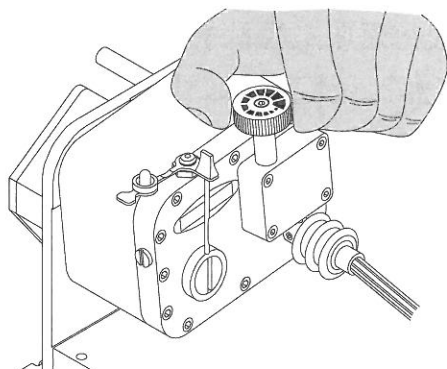

## 調整角度

Adjusting angle

Einstellen des auflagenwinkels

Réglage de l'angle

Asustase del angulo

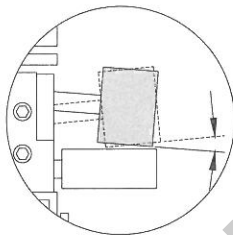
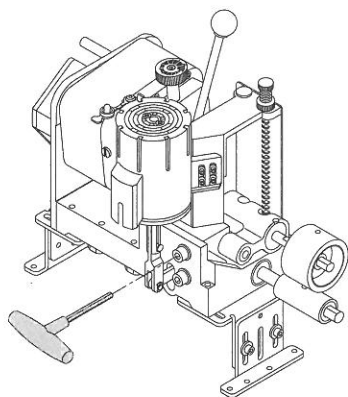

## 提昇量調整

Adjusting height level

Einstellen der höhe

Réglage de la hauteur

Asustase del nivel superior

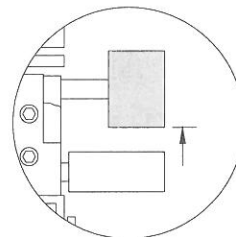
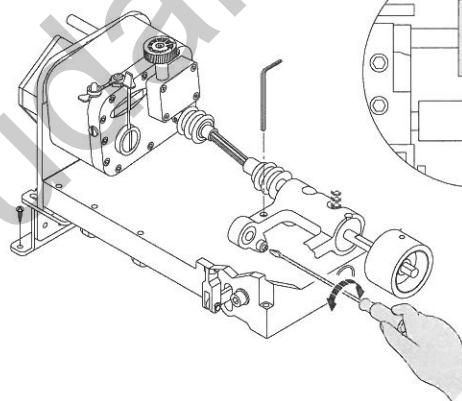

## 拉布機角速度圖

ROLLER SPEED

GESCHWINDIGKEIT DER ROLLE

VITESSE DU ROULEAU

VELOCIDAD DEL RODILLO

P-2 一般用 (標準型)

General use (standard type)

Für den Allgemeingebrauch (Standardmodell)

Usage général (type régulier)

Uso general (tipo estándar)

針棒上下曲線

Needle

Nadel

Aiguille

Aguja

變速機角速度

Puller speed

Geschwindigkeit der

Einzugsvorrichtung

Velocidad del rodillo

針板

Needle plate

Stichplatte

Plaque à aiguille

Placa de aguja

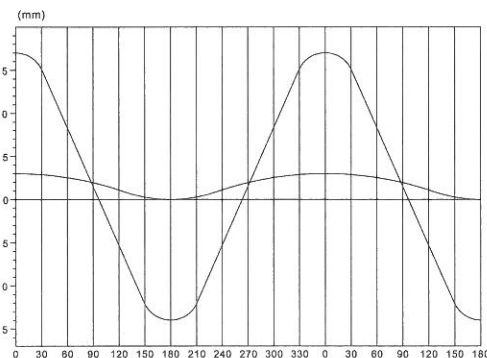

PULLERS 接線圖

WIRING DIAGRAM

SCHALTPLAN

SCHEMA DE CABLAGE

DIAGRAMA DE CABLEADO

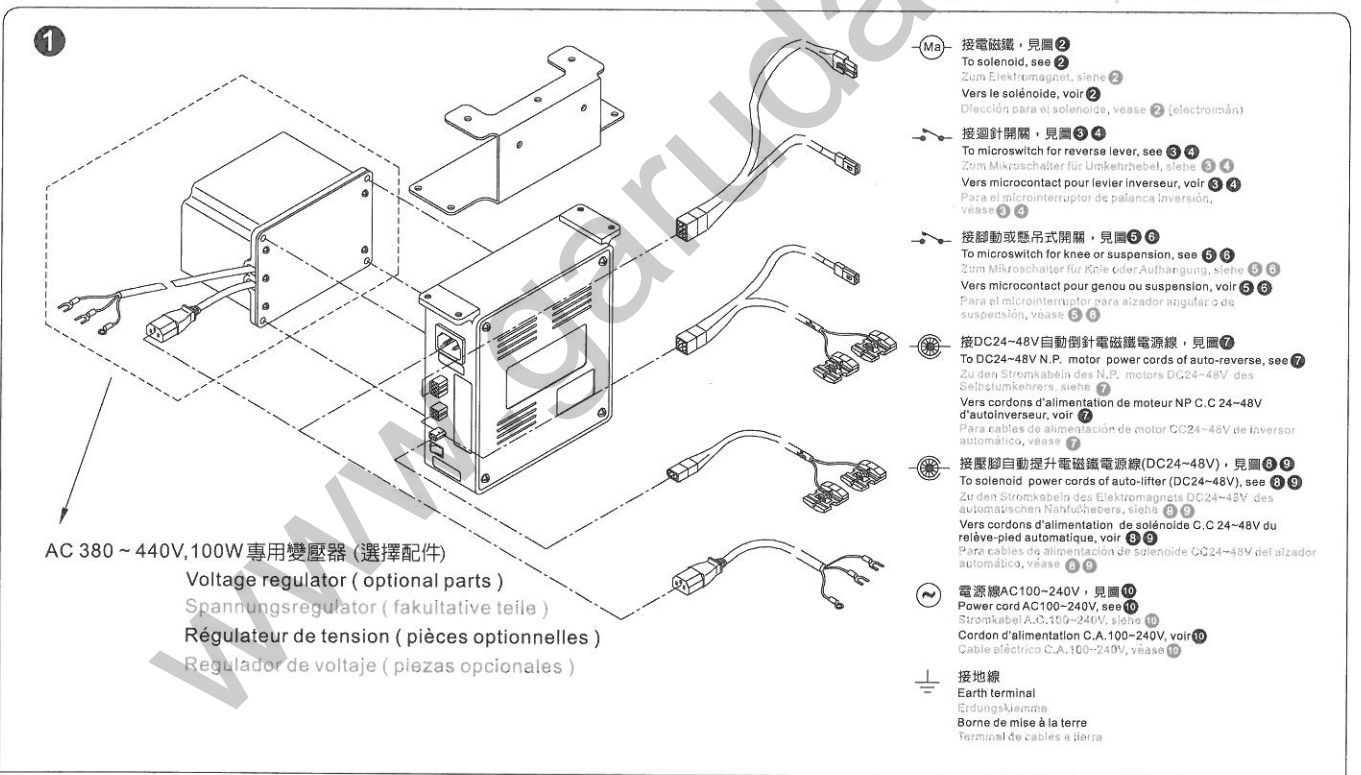
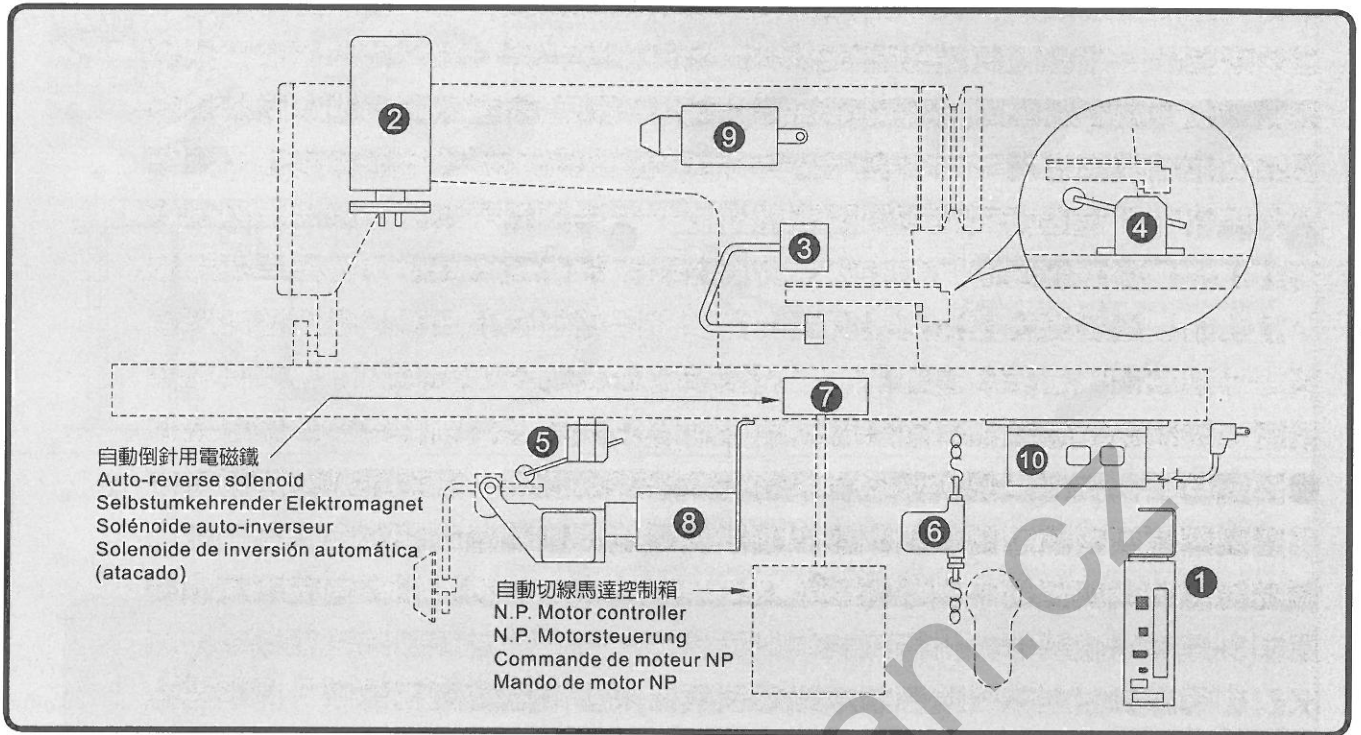

例 1  
Example 1  
Beispiel 1  
Exemple 1  
Ejemplo 1

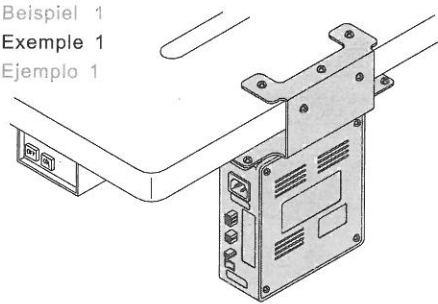

例 2  
Example 2  
Beispiel 2  
Exemple 2  
Ejemplo 2

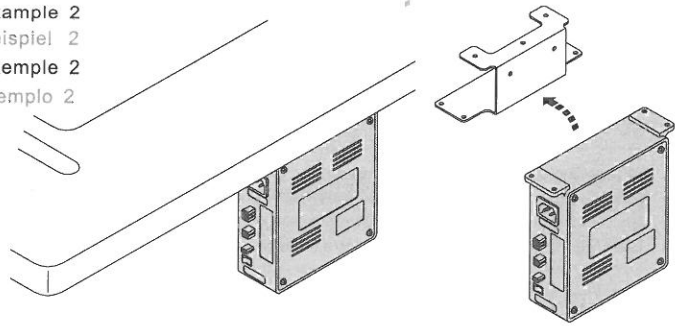

**2** 電磁鐵  
Solenoid  
Elektromagnet  
Solenoid  
Electroiman

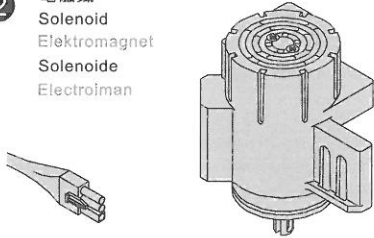

迴針開關之一  
Microswitch for reverse lever  
Mikroschalter für Umkehrhebel  
Microcontact pour levier inverseur  
Microinterruptor para palanca de inversión

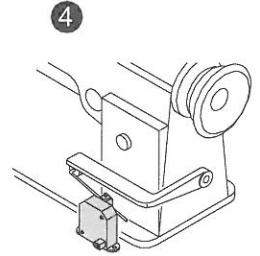
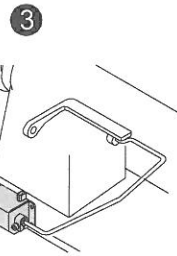
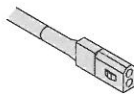

**5** 膝動開關  
Microswitch for knee presser foot lifter  
Mikroschalter für Knie/Fußhebel  
Microcontact pour relève-pied ( genou )  
Microinterruptor para alizador angular ( rodillera )

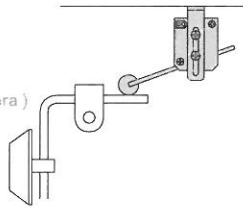
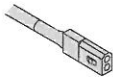

**6** 懸吊式開關  
Suspension microswitch  
Hängender Mikroschalter  
Microcontact suspendu  
Microinterruptor suspendido

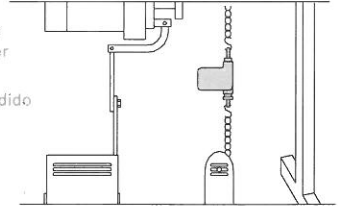

**7** 接於自動切線針車倒針用電磁電源上 (DC 24 ~ 48V)  
Finding and connecting the power cords of auto-reverse solenoid (DC24 ~ 48V)  
Suchen und Verbinden der Stromkabel für den selbstumkehrenden Elektromagnet (D.C.24 ~ 48V)  
Pour trouver et raccorder les cordons d'alimentation pour le solénoïde auto-inverseur (C.C.24 ~ 48V)  
Para localizar y conectar los cables eléctricos del solenoide de inversión automática (CD24 ~ 48V)

無自動切線之針車此線無需使用並將蓋子蓋上 (如圖)

For nonautomatic-trimming machine, keep this wire connector.

Bei Maschinen ohne Fadenschneider, Drahtanschlußstück zur Seite halten. Klemme wie gezeigt schließen.

Four machines sans coupe-fils, garder le raccorde-fil de côté. fermer le crampton tel qu'illustré ci-dessous.

En el caso de máquinas sin corta-hilos, guarde el conector de cable al lado. cerrar la pestillo tal como se indica en la ilustración.

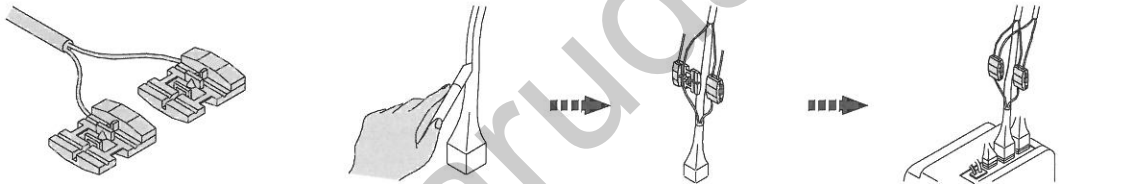

插頭形狀 Pin alignment Einstellung des Stifts Alignement du goujon Alineamiento del pin	針車廠牌 Machine brand Marke Marque Marca	適用機型 Applicable Models Verwendbare Modelle Modèles applicables Modelos aplicables	使用番號 Auto-reverse cord no. Nr. des Kabels mit autom. Freigabe No de cordon à dégageant auto Nº del cables de liberación automática
	JUKI	DDL-555-4 DDL-555-5 DDL-5550-6 DDL-5550-7 DDL-9000	(A) ③ ④ (B) ⑦ ⑧ (C) ⑥ ⑬
	BROTHER	BROTHER SERIES BROTHER S-7200	(B) ⑩ ⑪ (C) ⑤ ⑫
	SINGER	SINGER SERIES	(A) ① ②
	TOYOTA	LS2-AD158 DA-1200 SERIES	(A) ③ ④ (B) ① ④
	MITSUBISHI	LS2-180 DB189 LS2-190	(B) ⑪ ⑫

接壓腳自動提升電磁鐵電源線  
To solenoid power cords of auto-lifter  
Stromkabel des Elektromagnets für Fußhebel  
Cordons d'alimentation de solénoïde pour éleveur de pied  
Cables de alimentación de solenoide para alizador de pie

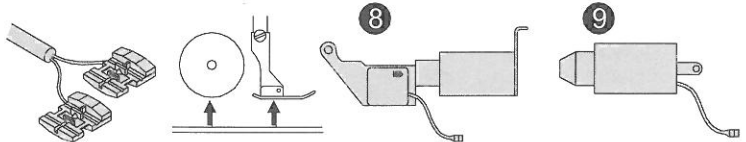

	JUKI	DDL-5550-7 DDL-9000 DDL-555-5	(A) ① ② (C) ③ ④
	BROTHER	BROTHER SERIES	(B) ① ④
	SINGER	SINGER SERIES	(C) ③ ④
	TOYOTA	DA-1200 SERIES	(B) ④ ⑥

**10** 電源線及地線 (電源 : AC100V~240V)  
Power cords and earth terminal (AC100V~240V power source)  
Stromkabel und Erdungsklemme (Stromversorgung A.C.100V~240V)  
Les cordons et la borne de mise à la terre (source d'alimentation CA100V~240V)  
Cables y terminal de conexión a tierra (suministro de energía eléctrica CA100V~240V)

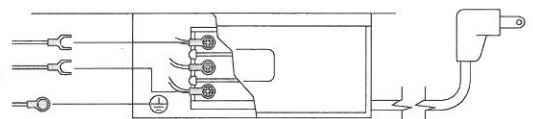



# PK 系列零件圖

## PARTS LIST FOR PK SERIES

### AUFLISTUNG DER TEILE DER SERIE PK

## LISTE DES PIÈCES DES SÉRIES PK

### LISTA DE RECAMBIOS DE LAS SERIES PK

**記號說明：**

Mark description :

Beschreibung :

Description :

Descripción :

標準配件·選擇使用

Standard parts, choose the suitable one

Standardteile

Pièces standards

Piezas estándares

選擇性配件

Optional parts

Fakultative Teile

Pièces optionnelles

Piezas opcionales

選擇性配件·請告知針車廠牌機型

Optional parts, please indicate sewing machine model no.

Fakultative Teile-bitte modellnummer der Nähmaschine angeben

Pièces optionnelles, veuillez indiquer le no de modèle de la machine à coudre

Piezas opcionales, indique por favor el numero de modelo de la máquina de coser

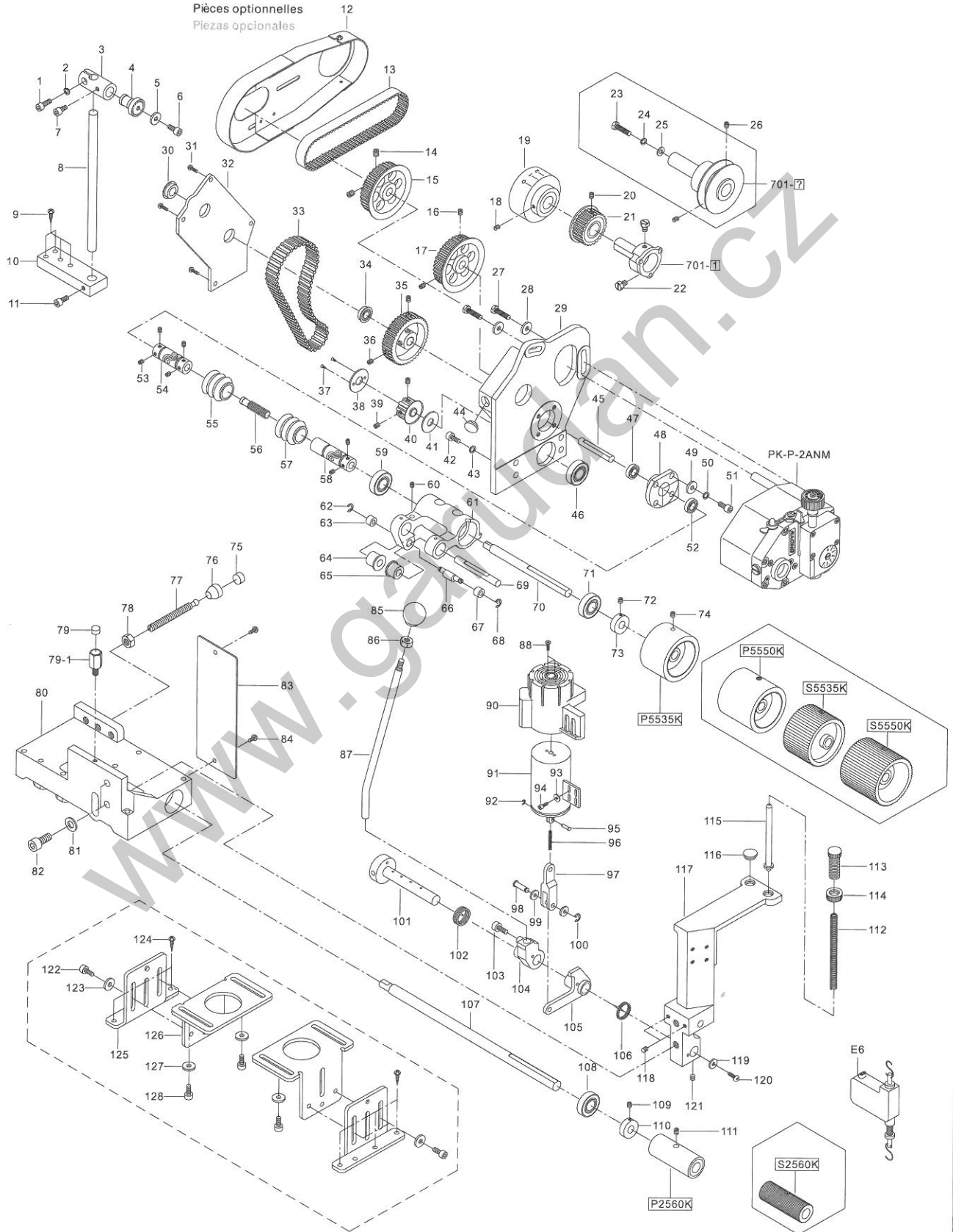

# 拉布輪編號圖

ROLLER LIST  
AUFLISTUNG DER ROLLEN

LISTE DES ROULEAUX  
LISTA DE RODILLOS

## 上輪 Upper roller Obere rolle

## Rouleau supérieur Rodillo superior

編號 Item Artikel Article Modelo	適用機型 Suitable Verwendbar für	Convient pour Sustituible	編號 Item Artikel Article Modelo	適用機型 Suitable Verwendbar für	Convient pour Sustituible
P2510 	PS	單針車專用 Single needle 1 Nadel Une aiguille Una aguja	T5550 	PL <span style="border: 1px solid black; padding: 2px;">PL-S2</span> PT	
P2515 	PS	雙針車專用 Twin needle Zwillingsnadel Deux aiguilles Dos agujas	P7015 	PL PF	
P5515 	PL PT <span style="border: 1px solid black; padding: 2px;">PF</span>		P5515K 	PK PY	
P5535 	PL PT		P5535K 	<span style="border: 1px solid black; padding: 2px;">PK</span> PY	
P5550 	PL <span style="border: 1px solid black; padding: 2px;">PL-S1</span> <span style="border: 1px solid black; padding: 2px;">PT</span>		P5550K 	PK <span style="border: 1px solid black; padding: 2px;">PY</span>	
S5515 	PL PT PF		S7015 	PL PF	
S5535 	PL PT		S5535K 	PK PY	
S5550 	PL PT		S5550K 	PK PY	

## 下輪 Lower roller Untere Rolle Rouleau inférieur(du bas) Rodillo de la parte inferior

P2580 	<span style="border: 1px solid black; padding: 2px;">PT</span>		P2580K 	<span style="border: 1px solid black; padding: 2px;">PY</span>	
P2560 	PL-S2		S2580K 	PY	
T2560 	<span style="border: 1px solid black; padding: 2px;">PL-S2</span>		P2560K 	<span style="border: 1px solid black; padding: 2px;">PK</span>	
P3022 	<span style="border: 1px solid black; padding: 2px;">PF</span>		S2560K 	PK	

   : 標準配件  
Standard parts      Pièces standards  
Standardteile      Piezas estándares

**P** : PU膠  
Polyurethane      Polyuréthane  
Polyurethan      Poliuretano

**S** : 鋼  
Steel      Acier  
Stahl      Acero

**T** : 工程塑膠  
Engineering plastics      Plastiques d'ingénierie  
Technischer Kunststoff      Plásticos de ingeniería

**C** : 工程塑膠  
Engineering plastics      Plastiques d'ingénierie  
Technischer Kunststoff      Plásticos de ingeniería

# 電控配件編號圖

ELECTRIC COMPONENTS  
ELEKTRISCHE KOMPONENTEN

COMPOSANTES ÉLECTRIQUES  
COMPONENTES ELÉCTRICOS

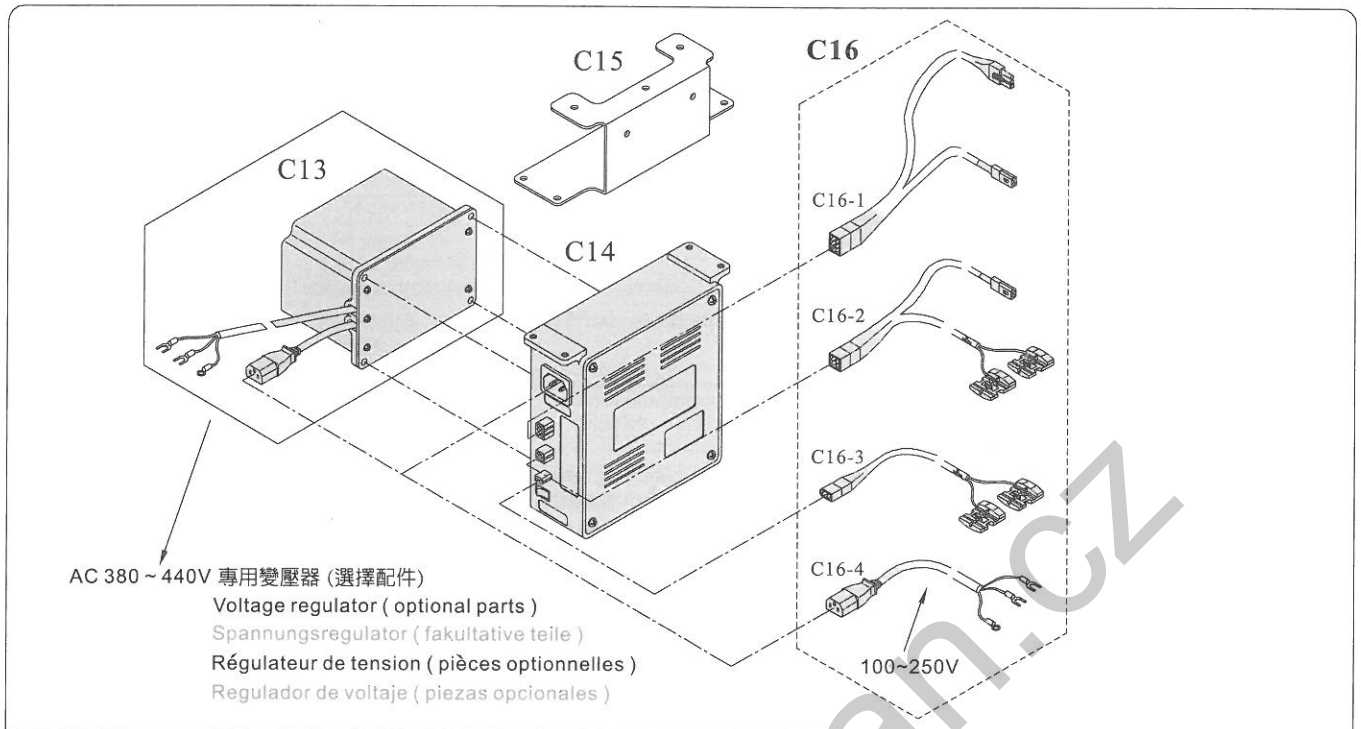

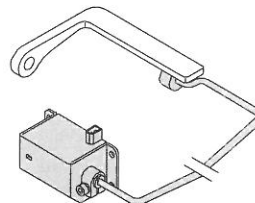
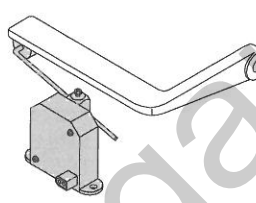
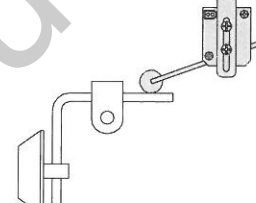
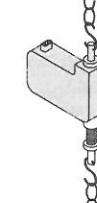
<p>E3 倒針開關之1 For reverse lever Für Umkehrhebel Pour levier inverseur Para palanca de inversión</p> 	<p>E4 倒針開關之2 For reverse lever Für Umkehrhebel Pour levier inverseur Para palanca de inversión</p> 	<p>E5 膝動開關 For knee lifter Für kniehebel Pour actionneur au genou Para alzador angular ( rodillera )</p> 	<p>E6 懸吊式開關 Suspension type Für das schwebende Modell Pour modèle suspendu Para modelo suspendido</p> 
--	--	---	---

# 氣控組件

AIR COMPONENTS  
LUFTZUFHRTEILE

COMPOSANTES PNEUMATIQUES  
COMPONENTES NEUMÁTICOS

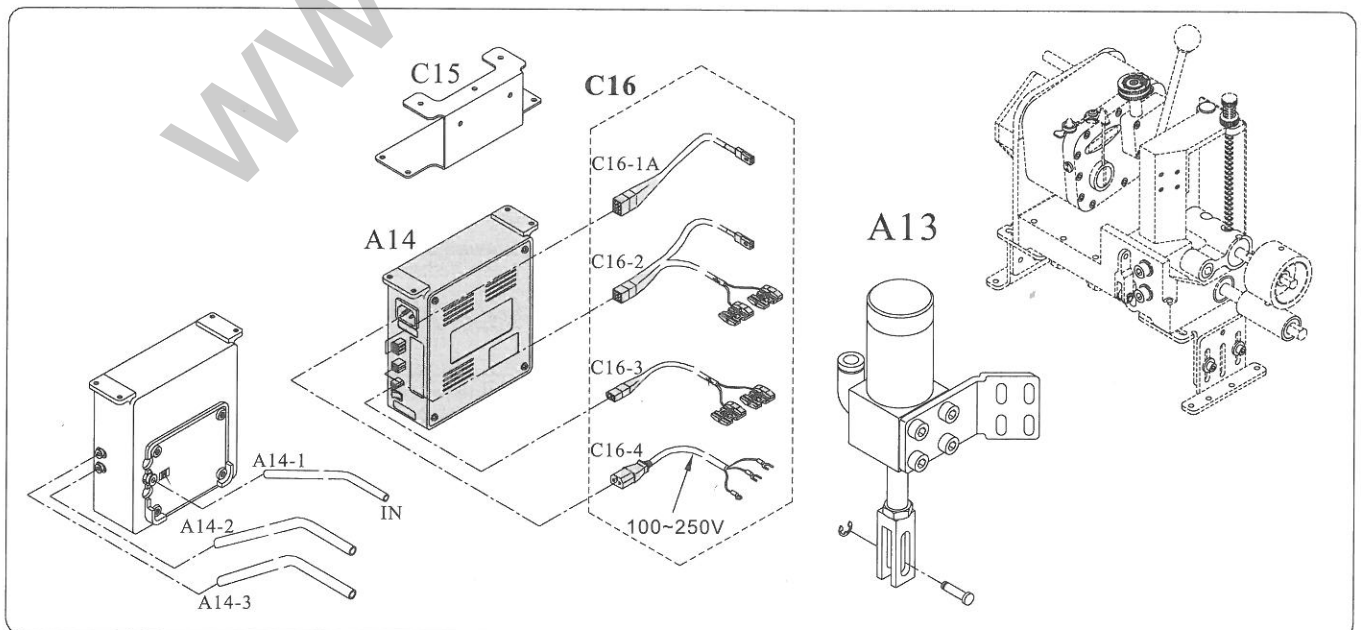

# 故障排除

SOULTION FOR ERROR FUNCTION  
PROBLEMLÖSUNG

SOLUTION DES PROBLEMES

LOCALIZACIÓN DE PROBLEMAS DE FUNCIONAMIENTO

現 象	原 因	解決方法
拉布機異常振動	1.拉布機與縫紉機銜接的螺絲鬆弛	1.參照 ①~②-5 重新固定
拉布輪與縫紉機送齒動作不同步	1.變速機入力軸與縫紉機定位不正確 2.縫紉機螺柱及時規皮帶齒輪螺絲鬆弛 3.時規皮帶鬆弛	1.參照 ②-6 重新定位 2.上緊鬆弛螺絲 3.參照 ②-5 重新調整
拉布輪異常耗損	1.拉布輪轉動速度太快 (拉布輪為PU製品，會隨時間老化，請勿久存)	參照第 4 頁重新調整
拉布速度快慢不均勻或停止動作	1.各傳動部份螺絲鬆弛 2.時規皮帶鬆弛 3.零件損壞	1.上緊鬆弛螺絲 2.參照 ②-5 重新調整 3.更換損壞零件
變速機漏油	1.變速機出入力軸纏繞異物 2.油封損壞 3.洩油孔螺絲鬆弛	1.去除異物 2.更換油封 3.上緊鬆弛螺絲
電磁鐵溫升異常 (正常80°C以下)	1.倒針或腳弓電磁鐵提升開關啓動間隙過小導致動作頻繁或延長動作時間	參照第 6 頁重新調整
電磁鐵控制失常或無法提升	1.控制系統故障 2.開關失常	1.更換控制盒 2.更換開關

保固期限：壹年，日期如無法查證時以出廠日期起18個月為準（不含時規皮帶及拉布輪等製品）

※ 變速機保養請參照變速機上標籤指示

Situation	Reason	Solution
Vibration	1.Fixed screw loosen	1. See fig. ① ~ ②-5
Un-syncom between pulling & feeding	1.Wrong position for transmission & sewing machine shaft 2.Screw for stud & timing belt gear loosen 3.Timing belt loosen	1. See fig. ②-6 2. Tighten the screw 3. See fig. ②-5
Un-normal worn out for roller	1.Roller's RPM too fast (Roller is made by PU, will naturely worn out, do not stock for long time)	See page 4
Stop pulling or unsteadable pulling	1.Screw loosen 2.Timing belt loosen 3.Parts damage	1. Tighten the screw 2. See fig. ②-5 3. Replace parts
Transmission oil leaking	1.Thread wrapped in transmission input or output shaft 2.Oil seal worn out 3.Bottom oil hole's screw loosen	1. Get rid of thread 2. Replace seal 3. Tighten the screw
Solenoid's temperature too high ( Normal is 80 °C )	1.The operate distance for back stitch switch or knee lifter switch is too short	See page 6
Solenoid out of function	1.Electric control system error 2.Switch out of order	1. Replace the control box 2. Replace switch

Warranty: One yaer, or 18 months after manufactured date ( Roller & timing belt not under warranty )

※ As transmission care, please follow instruction sticked on transmission

Problem	Ursache	Lösung
Vibriieren	1.Lockere Schrauben anziehen	1. Siehe ① ~ ②-5
Einzug und Zufuhr nicht in Einklang	1.Falsche Stellung der Welle von Übertragungsgetriebe und Nähmaschine 2.Schraube für Stift und Übertragungsriemen locker 3.Übertragungsriemen locker	1. Siehe ②-6 2. Schraube anziehen 3. Siehe ②-5
Ungewöhnlicher Verschleiß der Rolle	1.R.P.M. der Rolle zu hoch (Die Rolle nutzt nach und nach ab. austauschen wenn notwendig)	Siehe seite 4
Kein Einzug bzw. Ungleichmäßiger Einzug	1.Die Schraube ist locker 2.Übertragungsriemen locker 3.Beschädigte Teile	1. Schraube anziehen 2. Siehe ②-5 3. Teile austauschen
Auslaufen von Übertragungsöl	1.Faden in der Antriebsoder Abtriebswelle des Übertragungsgetriebes eingeklemmt 2.Öldichtung defekt 3.Schraube des unteren Öllochs locker	1. Faden lösen 2. Dichtung austauschen 3. Schraube anziehen
Temperatur des Electromagnets zu hoch ( Normal = 80 °C )	1.Der Abstand zur Betätigung des Rückstichschalters oder Kniehebels ist zu kurz. der Mikroschalter-Freiraum ist für den Umkehrhebel oder Kniehebel zu kurz	Siehe seite 6
Der Elektromagnet funktioniert nicht	1.Systemfehler in der elektrischen Steuerung	1. Steuerungskasten auswechseln

Garantie: 1 jahr bzw. 18 monate nach dem Fabrikationsdatum. Rollen und Übertragungsriemen fallen nicht unter diese Garantie.

※ Zur Wartung des Übertragungsgetriebes den entsprechenden Anweisungen folgen.

Probleme	Raison	Solution
Vibration	1. Serrer les vis desserrées	1. Voir la fig. ① ~ ②-5
Entraînement et alimentation désynchronisés	1. Mauvaise position d'arbre de machine à coudre et transmission 2. Vis du goujon et d'engrenage de courroie de distribution desserrées 3. Courroie de distribution lâche	1. Voir la fig. ② -6 2. Serrer les vis 3. Voir la fig. ② -5
Usure anormale du rouleau	1. RPM du rouleau trop rapide (Le rouleau s'usera naturellement. le changer au besoin)	Voir la page 4
Pas d'entraînement ou entraînement inégal	1. Vis desserrée 2. Courroie de distribution lâche 3. Pièces endommagées	1. Serrer les vis 2. Voir la fig. ② -5 3. Remplacer les pièces
Fuite d'huile de transmission	1. Fil emprisonné sur l'arbre d'entrée ou de sortie de transmission 2. Joint d'étanchéité à l'huile usé 3. Vis du trou d'huile du bas desserrée	1. Dégager le fil 2. Remplacer le joint 3. Serrer les vis
Température du solénoïde trop haute (température normale 80°C)	1. L'espace libre du microcontact est trop petit pour le levier inverseur ou l'actionneur au genou	Voir la page 6
Solénoïde défectueux	1. Erreur du système de contrôle électrique	1. Remplacer la boîte de contrôle

Garantie: Un an , ou 18 mois après la date de fabrication ( le rouleau et la courroie de distribution ne sont pas garantis)

※ Pour entretenir la transmission, suivre les instructions qui la concernent.

Problema	Razón	Solución
Vibración	1. Apretar los tornillos flojos.	1. Véase dibujo ① ~ ②-5
Tracción y avance fuera de sincronización	1. Mala posición de la transmisión y del eje de la maguina. 2. Aflojamiento de los tornillos del perno y del engrane de la correa de sincronización. 3. Correa de sincronización floja.	1. Véase dibujo ② -6 2. Apretar los tornillos 3. Ver dibujo ② -5
Desgaste abnormal del rodillo	1. RPM del rodillo demasiado rápida (El rodillo tiene un desgaste natural. cambiar según la necesidad)	Véase página 4
Ausencia de tracción o avance desigual	1. Tornillo flojo 2. Correa de sincronización floja. 3. Piezas dañadas	1. Apretar los tornillos 2. Véase dibujo ② -5 3. Cambiar las piezas
Perdida de aceite de transmisión	1. Hilo enganchado sobre el eje de entrada o de salida de la transmisión. 2. Junta de estanquidad del aceite gastada. 3. Perdida del tornillo del orificio interior del aceite.	1. Liberar el hilo 2. Cambiar la junta 3. Apretar los tornillos
Temperatura demasiada alta del solenoide (Normal = 80°C)	1. Distancia para activar el interruptor de despunte o del alzador angular demasiado corta. El espacio libre del microinterruptor es demasiado pequeño para la palanca de inversión o para el accionamiento del alzador angular.	Véase página 6
Solenoide defectuoso	1. Error del sistema de mando eléctrico	1. Substituir la caja de mando eléctrico

Garantía : Un año o 18 meses después de la fecha de fabricación (no hay garantía sobre el rodillo y la correa de sincronización).

※ Para el cuidado de la transmisión, haga el favor de seguir la instrucciones sobre la transmisión.

[www.garudan.cz](http://www.garudan.cz)